

INSTALLATION INSTRUCTIONS FOR PLUG-IN BOOSTER CABLES

For Top Mount Batteries (ALL HARDWARE INCLUDED)

1. Remove bolts from service vehicle battery and discard. Use new bolts included with the Booster Cables.
2. Attach new Bolt(3), Spacer(5) and Nut(4) for both pos. "+" and neg. "-" battery terminal hook-ups as shown. Be careful to attach the positive cable (the cable with the red stripe on the terminal end) to the positive post on the battery, as well as the negative cable to the negative post.

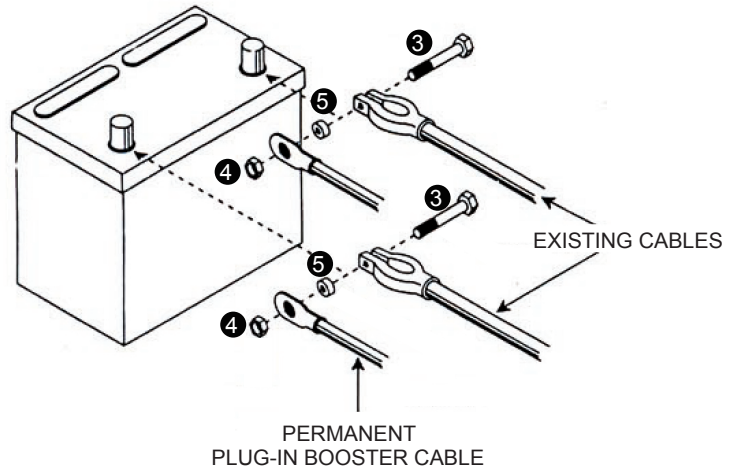

For Side Mount Batteries (ALL HARDWARE INCLUDED)

1. Remove bolts from service vehicle battery and discard. Use new Bolt(6), Spacer(8) and Nut(7) included with the Booster Cables.
2. Attach the battery cables with the new Bolts(6) (one "screw-in-screw" side terminal bolt for each terminal hook-up).
3. Attach booster cables to terminal bolt as shown right. Be careful to attach the positive cable (the cable with the red stripe on the terminal end) to the positive post on the battery, as well as the negative cable to the negative post.

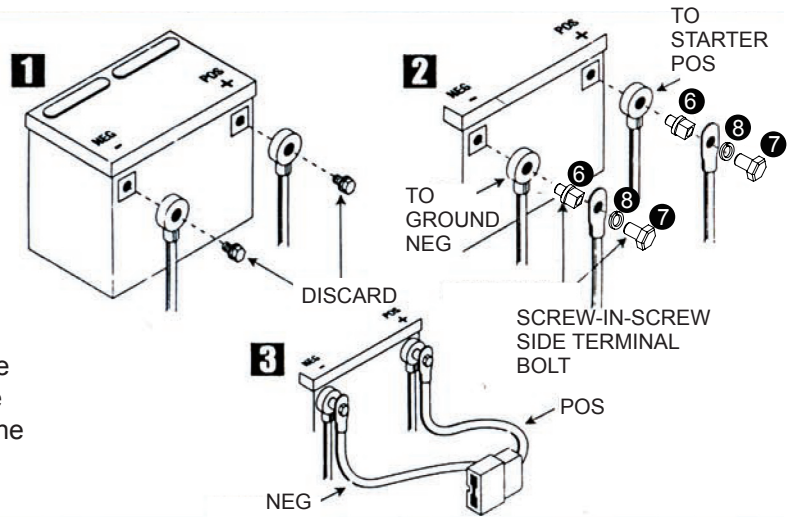

Bolt(9) and Nut(10) are used for attaching the Plug-in Connector to the vehicle. Cap(2) is used for protecting the Plug-in Connector from water and dust during storage.

PARTS LIST:

No.	Description	Qty	No.	Description	Qty
1	Booster cable	1	6&7	Screw-in-crew Side Terminal Bolt	2
2	Cap	1			
3	Bolt(M)	2	8	Copper Spacer	2
4	Nut(M)	2	9	Bolt(S)	2
5	Aluminum Spacer	2	10	Nut(S)	2

